

# Auto Geometry Adjustment System

自动几何调整系统

VS-5140-GEOM

## Outline

Being specially designed with Single Camera vision system, the Geometry Inspection System provides distortion measurements of keystone, Trapizan, parallel, linearity, & pincushion with high accuracy and real time adjustment.

Integrated with IIC communication protocol, the system provides automatic adjustment of TV's distortion through the IIC bus.

## What's New?

### 1. Frame Grabber / Picture Analyzer

*Instead of Panasonic VS-6120A,*

Now, we are using :

*Matrox Meteor-II/Multi-Channel*



- ♣ **Low-cost frame grabber Cards** for component RGB interlaced or progressive Scan Video Aquisition.
- ♣ Support for Microsoft® Windows® 98, Windows NT® 4.0, Windows® 2000 Windows® Me, and Windows® XP

### 2 ASTRO Video Signal Generator



- ♣ for Multi\_ Video Signal Format:
  - HDTV (SMPTE274M, 296, & 240),
  - Composition Video ( PAL & NTSC)
  - S\_Video
  - YPbPr & VGA
- 3 Operation Interface is compatible with Existing system;

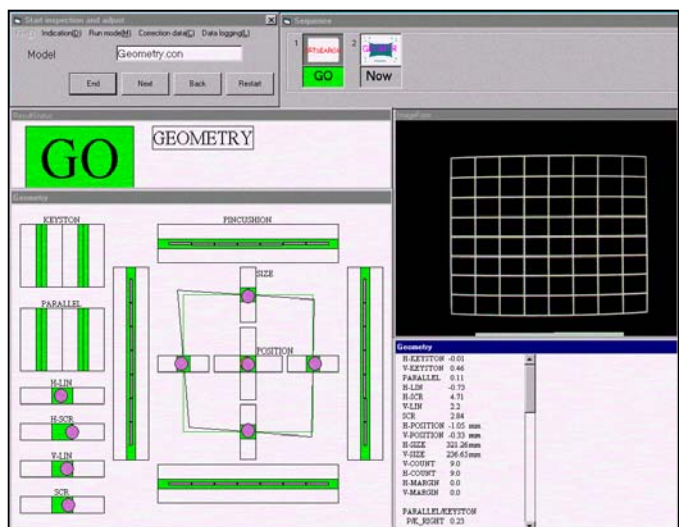
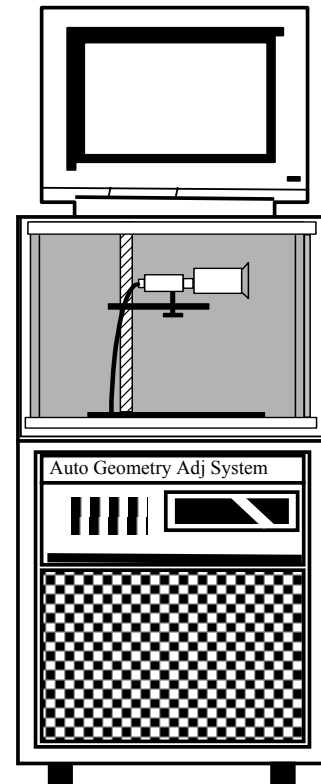

# Technical Specification

## 1. General Specification

<b>System Components</b>	
Industrial Computer (PentiumIII 933MHz or more)	Video Signal Generator Module
1-CCD Camera (640x480) System	Operator Control Box
Picture Analyser Module (16 bits DSP, 60MHz)	Camera Tripod & X-Y Adjustor
AV Control Module(DIO, IIC Control)	
<b>Device Under Test (DUT)</b>	
CRT Size	14" ~ 36"
Aspect Ratio	Normal & Wide Screen
Video Mode	PAL
<b>Measurement</b>	
Resolution	0.1 mm
Accuracy	± 0.5 mm
<b>Power Supply</b>	
	230 VAC, 50 Hz
<b>Measurement Items</b>	
Raster Size, Pinchusion Linearity, Position	
S-Correction, Keystone, Parallel	
<b>Manual</b>	
Operation and Maintenance	
<b>Software</b>	
Auto Geometry Adjustment Software	
Measurement Condition File Editor	
( including Test Specification Entry)	
<b>Optional</b>	
Data Collection & Analysis Software	
Camera & Equipment Rack Frame	

## 2. System Configuration

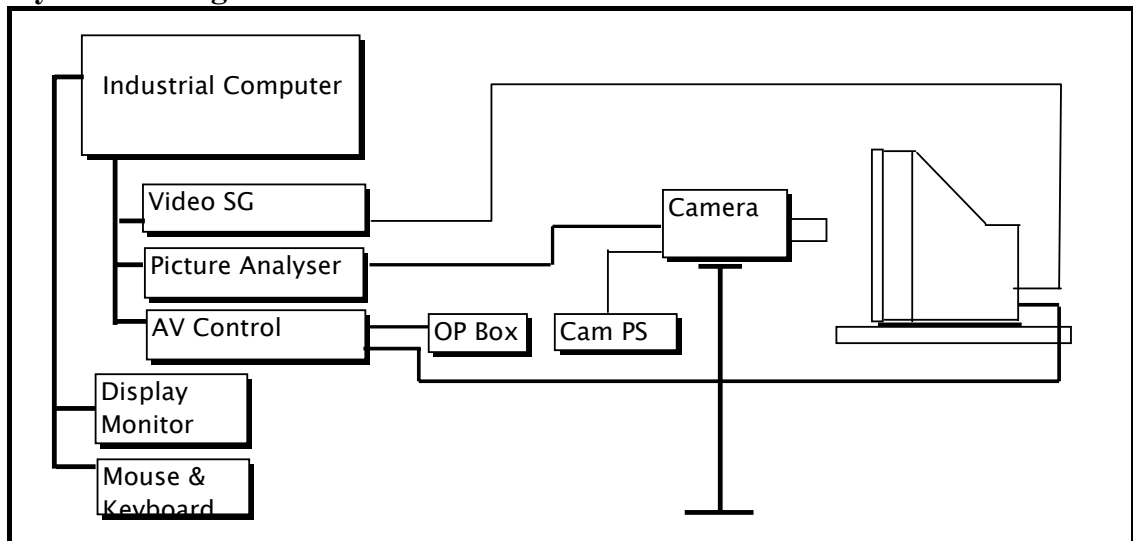

## 3. Curved surface correction

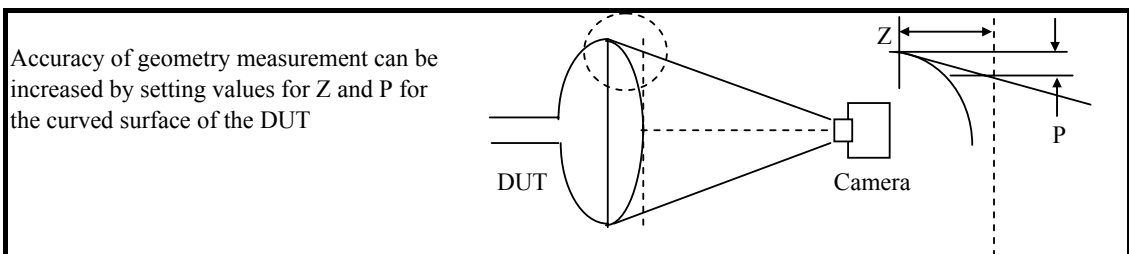

For future information, please contact:

Manufactory: (Reg. No. 200312647N)

**VISIONTEC**

**Industrial Vision Technology (S) Pte Ltd**  
Blk 67, #06-22/23, Ayer Rajah Crescent  
Singapore 139950

Tel: +65 6563 6110 Fax: +65 6563 1556  
email: sales@visiontec.com.sg